

# Power electronics for hybrid battery–supercapacitor PV storage systems: state-of-the-art converter topologies and future trends

Tole Sutikno<sup>1,2</sup> , Hendril Satrian Purnama<sup>2</sup> , Auzani Jidin<sup>3</sup> 

<sup>1</sup>Department of Electrical Engineering, Faculty of Industrial Technology, Universitas Ahmad Dahlan, Yogyakarta, Indonesia

<sup>2</sup>Embedded System and Power Electronics Research Group, Yogyakarta, Indonesia

<sup>3</sup>Faculty of Electrical Technology and Engineering, Universiti Teknikal Malaysia Melaka, Malacca, Malaysia

## Article Info

### Article history:

Received Feb 26, 2026

Revised Apr 27, 2026

Accepted May 12, 2026

### Keywords:

Converter topologies

Hybrid battery

Power electronics

Storage systems

Supercapacitor

## ABSTRACT

The rapid expansion of photovoltaic (PV) generation has intensified the need for energy storage systems capable of mitigating intermittency, voltage fluctuations, and dynamic load variations. While lithium-ion batteries (LIBs) provide high energy density and mature deployment pathways, their lifetime is significantly affected by frequent high-power transients and ripple currents under variable PV conditions. Hybrid energy storage systems (HESS) that combine batteries with supercapacitors (SCs) exploit complementary characteristics, high energy density from batteries and high-power density from SCs used to improve dynamic performance and extend lifespan. In many systems, power electronics serve as the critical enabling interface for bidirectional energy flow, voltage regulation, and power decoupling. This paper presents a comprehensive, converter-centric review of power electronic topologies for PV-based battery–SC HESS, systematically classifying passive, active, cascaded, isolated, non-isolated, dual-active-bridge, and multiport architectures. Their performance is compared and evaluated in terms of efficiency, voltage gain, power density, controllability, scalability, and impact on battery stress, with reported prototypes achieving peak efficiencies in the 95–98% range. Emerging trends, including wide-bandgap (WBG) semiconductor adoption, soft-switching operation, modular multiport integration, and predictive data-driven control, are identified as key enablers for next-generation high-efficiency and reliability-optimized PV–HESS systems.

This is an open access article under the [CC BY-SA](https://creativecommons.org/licenses/by-sa/4.0/) license.



## Corresponding Author:

Tole Sutikno

Department of Electrical Engineering, Faculty of Industrial Technology, Universitas Ahmad Dahlan

4<sup>th</sup> UAD Campus, Ahmad Yani St. (Southern Ring Road), Tamanan, Yogyakarta 55191, Indonesia

Email: tole@mail.com

## 1. INTRODUCTION

The global deployment of photovoltaic (PV) systems has accelerated rapidly over the past decade as part of efforts to decarbonize electricity generation and electrify energy systems. The intermittency of solar irradiance due to daily cycles, weather variations, and phenomena such as partial shading causes significant challenges to reliable power delivery. Fluctuations in output of PV can cause rapid changes in generation that must be balanced with load demand or grid requirements, especially in off-grid and microgrid environments. This variability complicates voltage regulation, frequency control, and power quality, particularly when PV penetration levels exceed local demand or conventional balancing capacity. Addressing these challenges necessitates robust energy storage solutions that can support both high-energy and high-power demands associated with PV intermittency [1].

Batteries particularly lithium-ion chemistries are widely used for PV energy storage due to their high energy density and relatively mature cost structure. However, they exhibit inherent limitations that constrain performance in high-variability contexts, such as:

- Finite lifetime and degradation: frequent cycling and high charge/discharge currents accelerate capacity fade, reducing operational life and increasing maintenance costs. Conventional batteries often require replacement every 3–5 years in solar applications if used without mitigation of transient stress [2].
- Power density limitations: batteries are optimized for sustained energy delivery rather than rapid power bursts. Under fast load changes or irradiance variations, batteries are forced to provide peak power beyond their optimal range, resulting in increased internal resistance, heat generation, and reduced efficiency [3].
- Battery stress under dynamics: in PV systems with significant fluctuations, the stress imposed on batteries by frequent ramping events can further shorten cycle life and reduce reliability. This necessitates oversizing or advanced management strategies to protect battery health [1].

Hybrid energy storage systems (HESS) that combine batteries with supercapacitors (SCs) have emerged as a promising solution to these limitations by exploiting the complementary characteristics of both technologies. In a typical HESS configuration, batteries contribute high energy density and sustained energy delivery necessary to meet the majority of the daily energy balance. Meanwhile, SCs provide high power density, rapid charge/discharge capability, and extremely long cycle life often exceeding several hundred thousand cycles which effectively absorb power transients and support peak demands without significant degradation [4].

This combination allows SCs to smooth fast fluctuations in PV output, significantly reducing the instantaneous current load on the battery and thereby extending battery lifetime and operational reliability. For example, empirical and simulation studies have shown that hybridization can reduce battery cycling stress and maintain more stable states of charge under dynamic PV conditions [5]. Additionally, tailored energy management strategies can optimize energy distribution and leverage the dynamic response of SCs to balance short-term variability with long-term storage needs [3].

Power electronics constitute the core enabling technology for integrating PV generation with hybrid battery–HESS, as they govern energy flow management, voltage regulation, and power decoupling among system components with fundamentally different dynamic behaviors. Due to the intermittent and nonlinear nature of PV output, DC–DC converters equipped with maximum power point tracking (MPPT) are required to continuously extract optimal power while maintaining a stable DC bus for downstream storage and loads. In PV–HESS architectures, bidirectional converters further enable controlled charging and discharging of batteries and SCs, allowing fast power transients to be absorbed by the SCs while reserving the battery for long-duration energy balancing. This active power decoupling mitigates voltage ripple, improves power quality, and prevents high-frequency current components from propagating into the battery, thereby enhancing system stability under rapid irradiance and load variations [6], [7].

This paper focus on the power electronic interface of PV based hybrid battery–HESS, with particular emphasis on converter topologies, control strategies, and emerging technological trends. Unlike many existing surveys that primarily address hybrid storage from electrochemical or energy management perspectives, this paper adopts a converter-centric approach, systematically classifying non-isolated, isolated, interleaved, dual active bridge, and multiport architectures, and linking their structural characteristics to efficiency, power density, dynamic response, and battery lifetime implications. It further evaluates control strategies from conventional PI and droop methods to model predictive and AI-assisted techniques within the context of topology-dependent performance trade-offs. By integrating quantitative benchmarking with analysis of wide-bandgap (WBG) device adoption, modular designs, and digitalized control frameworks, this review provides a structured and forward-looking reference for the design of next-generation PV–HESS power conversion systems.

## 2. FUNDAMENTALS OF PV-BASED HYBRID BATTERY–SC STORAGE SYSTEMS

### 2.1. Architecture of photovoltaic–hybrid energy storage systems-systems

PV–HESS are generally implemented using either DC-coupled or AC-coupled configurations, each with distinct performance and integration implications. In DC-coupled architectures, PV arrays and hybrid storage units are connected to a common DC bus through dedicated DC–DC converters before interfacing with a grid-tied inverter. This structure reduces redundant conversion stages, improves round-trip efficiency, and enables tighter coordination between MPPT control and bidirectional energy management—features particularly advantageous for battery–SC hybridization in microgrids and off-grid systems [8], [9]. Conversely, AC-coupled systems integrate storage on the AC side via independent inverters, offering flexibility for retrofitting existing PV installations and independent operational control, albeit at the cost of additional conversion losses and increased synchronization complexity [10].

From a structural perspective, PV–HESS can be organized into centralized, distributed, or modular architectures. Centralized configurations aggregate PV and hybrid storage through a single conversion interface, simplifying control but limiting redundancy. Distributed architectures employ multiple localized converters, improving scalability, dynamic performance, and fault tolerance in microgrid environments [11]. More recently, modular and multiport converter (MC)-based architectures have attracted attention for integrating PV, batteries, and SCs within a unified high-frequency structure, reducing component duplication while enhancing power density and expandability [12]. The selection among these architectures involves trade-offs among efficiency, control complexity, scalability, and reliability, making architectural design a foundational consideration in high-performance PV–HESS deployment. Figure 1 shown the general architecture of PV–HESS systems.

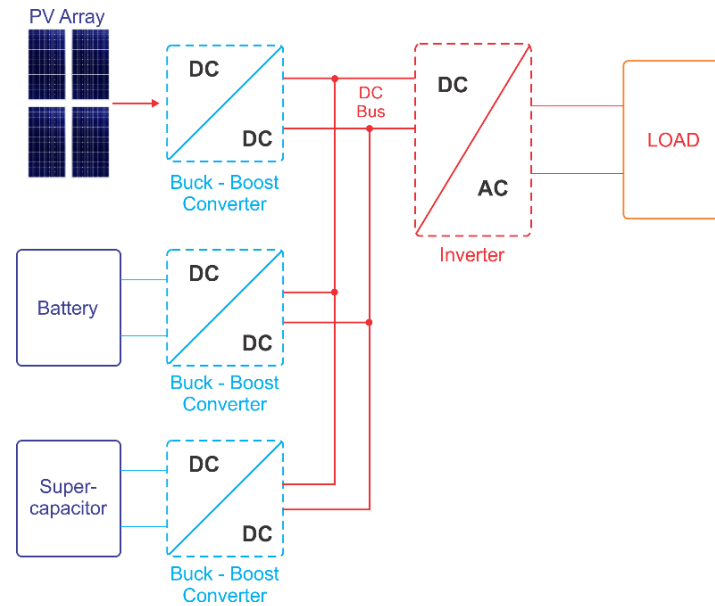

Figure 1. Architecture of PV–HESS systems

## 2.2. Characteristics of batteries and supercapacitors

Lithium-ion batteries (LIBs) are characterized by high energy density (typically 150–250 Wh/kg at pack level) and relatively high round-trip efficiencies (>90%), making them suitable for sustained energy delivery in PV and EV applications; however, their power density is limited compared to electrochemical capacitors, and degradation remains a major constraint [13], [14]. Recent studies classify degradation mechanisms into loss of lithium inventory (LLI), loss of active material (LAM), and conductivity loss (CL), driven by cycling, high C-rate operation, temperature, and depth-of-discharge stress [13], [15]. Calendar and cyclic aging phenomena progressively increase internal resistance and reduce usable capacity, with end-of-life commonly defined at 80% of nominal capacity [13], [14]. Advanced nickel-rich chemistries (e.g., nickel manganese cobalt (NMC)) further highlight structural instability and surface reactivity as dominant failure pathways under high-voltage operation [15], [16]. These mechanisms directly limit lifetime under highly fluctuating PV load profiles, particularly when subjected to frequent high-power transients.

In contrast, SCs exhibit very high-power density (kW/kg range), fast charge–discharge capability (seconds scale), excellent cycle life (>10<sup>5</sup>–10<sup>6</sup> cycles), and wide temperature tolerance, albeit with substantially lower energy density (typically 5–20 Wh/kg) [17]–[19]. Recent material advances, including pseudocapacitive nanostructures and graphene-based electrodes, have improved volumetric capacitance and cycling stability while maintaining high-rate capability [20], [21]. Because SCs are less sensitive to high current pulses and depth-of-discharge stress, they are particularly suitable for transient power buffering. Consequently, hybrid battery-SC energy storage systems (HESS) exploit the complementary characteristics of both technologies: the battery provides bulk energy capacity, while the SC mitigates peak currents and power fluctuations, reducing battery stress and extending cycle life [17], [22]. Experimental and optimization

studies consistently report measurable reductions in battery peak current and improved lifetime when appropriate energy management strategies are implemented [22].

### 2.3. Power electronics requirements for photovoltaic–hybrid energy storage systems

Power electronic interfaces in PV–HESS must ensure bidirectional power flow, wide voltage operating range, high efficiency under partial-load conditions, and long-term reliability with modular scalability. Bidirectional DC–DC converters are essential to coordinate charge–discharge cycles between batteries and SCs while stabilizing the DC bus during PV intermittency; recent comprehensive reviews emphasize their central role in HESS lifetime extension and dynamic power decoupling [23]. Experimental prototypes of high-performance bidirectional converters report efficiencies of 98.4% in multiport non-solitary designs [24] and up to 98.6% in high-gain coupled-inductor structures [25]–[27], demonstrating state-of-the-art performance benchmarks. Wide voltage conversion capability is required due to PV MPPT variability and the broad SoC-dependent voltage window of both batteries and SCs [28], [29]; recent dual-active-bridge implementations for PV–BESS achieve >95.8% efficiency with 10:1 voltage gain (60–600 V) [30], while high-gain KY-based bidirectional converters reach 97.67–99.22% efficiency in discharge mode [31]. Under partial-load operation, common in PV applications, soft-switching and interleaved topologies reduce switching loss and ripple stress, as shown in recent soft-switching bidirectional converters [32], [33]. Finally, reliability and scalability benefit from multiport and modular architectures that reduce component count and semiconductor stress while enabling expandable HESS integration in DC microgrids [34]. Collectively, these requirements highlight that converter topology selection directly governs efficiency, dynamic response, thermal stress distribution, and ultimately the operational lifetime of PV–HESS systems.

## 3. CLASSIFICATION OF POWER CONVERTER TOPOLOGIES FOR PV–HESS

In PV–HESS system, power converter plays an important role to deliver the power smoothly from the PV source to HESS and the load. Therefore, classifying the types of power converters is a very important point in determining the selection of the type of converter that best suits the characteristics of the PV–HESS system developed. Figure 2 shows the power converter topologies for PV–HESS systems.

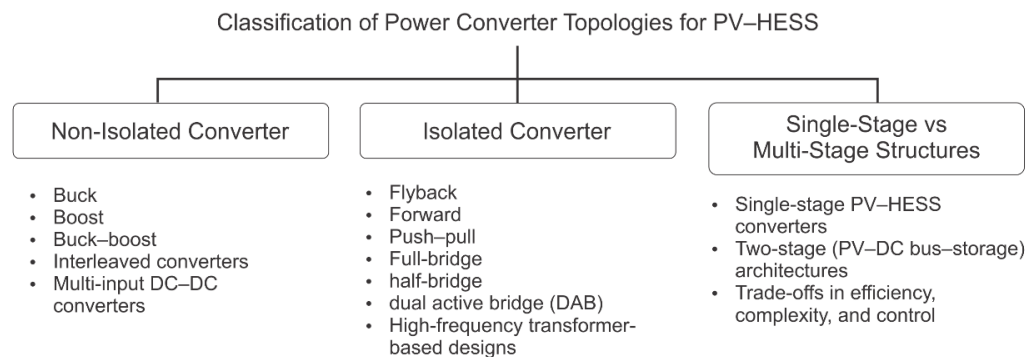

Figure 2. Classification of power converter topologies for PV–HESS

Figure 2 presents a structured classification of power converter topologies employed in PV–HESS, organized into three principal categories based on electrical isolation and system architecture. Non-isolated converters, including buck, boost, buck–boost, interleaved, and multi-input DC–DC configurations, are characterized by their simplicity, high efficiency, and compact design, but lack galvanic isolation, making them more suitable for low to medium power applications [26], [35]. In contrast, isolated converters, such as flyback, forward, push–pull, full-bridge, half-bridge, and dual active bridge (DAB) topologies, utilize high-frequency transformers to provide galvanic isolation, voltage scaling, and improved safety, albeit with increased complexity and cost. The third classification distinguishes between single-stage and multi-stage structures: single-stage converters directly integrate PV and storage interfacing within one conversion step, offering reduced component count and potentially higher efficiency, while multi-stage architectures separate PV and storage processing (e.g., via a DC bus), enabling enhanced control flexibility, modularity, and optimization at the expense of additional conversion losses and system complexity.

## 4. CONVERTER TOPOLOGIES FOR BATTERY–SUPERCAPACITOR HYBRIDIZATION

### 4.1. Passive hybridization topologies

Passive hybridization connects the battery and SCs directly in parallel to a common DC bus without dedicated converters, relying on their intrinsic impedance differences to achieve natural power sharing—where the SC handles high-frequency transients and the battery supplies low-frequency energy components. Although this configuration offers structural simplicity and low cost, it lacks controllability in current distribution and independent state-of-charge (SoC) regulation, limiting its effectiveness in mitigating battery stress under dynamic PV conditions. Recent reviews highlight that passive HESS structures provide limited lifetime extension due to insufficient ripple suppression and constrained dynamic control [36]-[38]. Consequently, passive approaches are generally suitable only for low-power or cost-sensitive applications where advanced energy management is not required.

### 4.2. Active hybridization topologies

Active hybridization employs bidirectional DC–DC converters to regulate power flow between the battery, SC, and DC bus, enabling controlled power decoupling and optimized current sharing. In partially active configurations, typically only the SC is interfaced through a converter, while the battery is directly connected; fully active architectures utilize separate converters for both storage elements, offering maximum control flexibility and superior ripple mitigation. Experimental studies report that actively managed HESS can reduce battery current ripple by more than 50% and extend cycle life by 20–40% under dynamic load profiles [39], [40]. Furthermore, recent developments in model predictive control (MPC) and adaptive energy management strategies improve dynamic response and efficiency in PV-integrated hybrid storage systems [41], [42], making active topologies the preferred solution for high-performance PV–HESS applications.

### 4.3. Multiport converter designs

MC architectures integrate PV, battery, and SC interfaces within a unified three-port or multiport DC–DC topology, reducing redundant conversion stages and enhancing system-level efficiency. Compared to conventional cascaded dual-converter approaches, MCs achieve lower component count, reduced conduction losses, and improved power density. Recent three-port bidirectional converters demonstrate peak efficiencies exceeding 97–98% while enabling flexible power allocation among storage ports [43], [44]. Dual-active-bridge-based and coupled-inductor multiport structures further provide high voltage adaptability and soft-switching capability, improving overall reliability and scalability [45], [46]. Comparative analyses confirm that multiport solutions outperform traditional separate-converter architectures in terms of volumetric power density and conversion efficiency, though they require more sophisticated control design and protection strategies.

Table 1 provides a high-level comparison of different DC–DC converter topologies commonly employed in PV–HESS applications. The comparison highlights trade-offs in isolation, switch count, control complexity, and achievable power density. Non-isolated converters remain attractive for small-scale PV systems due to their simplicity, while interleaved and MCs address higher current and integration needs. Isolated configurations such as flyback or DAB topologies are preferred in safety-critical or medium–high power applications where galvanic isolation is essential.

Table 1. High-level topology comparison

Topology category	Typical configuration	Isolation	Number of active switches	Control complexity	Power density	Typical applications
Non-isolated DC–DC	Buck/boost/buck–boost	No	Low	Low	Medium	Small-scale PV systems
Interleaved DC–DC	Multi-phase buck/boost	No	Medium	Medium	High	High-current PV–HESS
Isolated DC–DC	Flyback/full-bridge	Yes	Medium–high	Medium	Medium	Safety-critical systems
DAB	HF transformer-based	Yes	High	High	High	Medium–high power PV–HESS
MC	Three-port DC–DC	Optional	Medium	High	Very high	Integrated PV–HESS

## 5. CONTROL AND ENERGY MANAGEMENT STRATEGIES

### 5.1. Converter-level control techniques

Converter-level control in PV–HESS systems is typically implemented using voltage-mode control (VMC) and current-mode control (CMC) to regulate DC-link voltage and shape bidirectional current flow between the battery, SC, and DC bus. While VMC offers implementation simplicity, CMC provides faster transient response and inherent overcurrent protection, making it more suitable for ripple-sensitive hybrid

storage applications. In multi-converter PV–HESS microgrids, droop control is widely adopted to enable decentralized power sharing without communication links, whereas virtual impedance techniques enhance current sharing accuracy and suppress circulating currents. Recent studies report improved stability margins and dynamic performance when adaptive droop and virtual impedance compensation are applied in DC microgrids with hybrid storage [47]–[49]. These approaches remain foundational for scalable PV–HESS converter coordination.

### 5.2. Power sharing and energy management algorithms

Power sharing in battery–SC systems is commonly realized through frequency-based (low-/high-pass filter) and power-based splitting methods, where low-frequency power components are assigned to the battery and high-frequency transients to the SC to reduce battery stress. Frequency-decoupling techniques are computationally efficient and widely used, while power-based strategies incorporate load demand and SoC information for more adaptive allocation. Beyond heuristic approaches, rule-based energy management offers deterministic logic for charge/discharge decisions, whereas optimization-based strategies—such as dynamic programming and convex optimization—aim to minimize degradation cost and energy loss. Comparative studies show that optimization-based hybrid energy management can significantly reduce battery peak current and extend cycle life under stochastic PV conditions [50]–[53]. These methods form the core of hierarchical PV–HESS supervisory control.

### 5.3. Advanced and intelligent control approaches

Advanced control strategies, including MPC, fuzzy logic control (FLC), and neural-network-based methods, are increasingly employed to address the nonlinear and multi-objective nature of PV–HESS systems. MPC enables predictive current shaping and constraint handling, improving transient response and reducing battery ripple compared to conventional PI-based control [54]–[56]. FLC provide robustness under parameter uncertainty, while neural networks facilitate adaptive power allocation and state estimation. Recent reviews highlight the growing role of artificial intelligence and machine learning in hybrid energy storage management, including load forecasting, SoC estimation, and degradation-aware dispatch optimization [57], [58]. These intelligent approaches represent a transition toward predictive, data-driven energy management in PV–HESS microgrids.

## 6. PERFORMANCE METRICS AND COMPARATIVE EVALUATION

### 6.1. Efficiency, power density, and cost metrics

Performance evaluation of PV–HESS converters is primarily based on conversion efficiency, volumetric power density, and overall cost per kW, all of which are strongly influenced by semiconductor switching losses and magnetic component design. Conduction and switching losses in metal-oxide-semiconductor field-effect transistors (MOSFETs)/insulated gate bipolar transistors (IGBTs), core and copper losses in inductors/transformers, and parasitic effects determine full-load and partial-load efficiency profiles. The adoption of WBG devices such as silicon carbide (SiC) and gallium nitride (GaN) has enabled higher switching frequencies, reduced switching losses, and smaller passive components, thereby improving power density and system compactness. Recent surveys report efficiency improvements of 1–3% and significant reductions in magnetic volume when transitioning from Si to SiC/GaN devices in high-frequency DC–DC converters [59]. Moreover, techno-economic analyses indicate that although WBG devices increase initial semiconductor cost, lifecycle cost per kWh decreases due to higher efficiency and reduced cooling requirements.

### 6.2. Impact on battery lifetime and system reliability

Converter topology and control strategy directly influence battery lifetime and system reliability by shaping current ripple and thermal stress. High-frequency ripple currents accelerate electrochemical degradation mechanisms such as lithium plating and solid-electrolyte interphase (SEI) growth, reducing cycle life. Hybrid battery–SC configurations with properly controlled bidirectional converters significantly suppress low- and high-frequency ripple components, thereby extending battery lifespan. Experimental studies demonstrate that ripple mitigation strategies can reduce RMS battery current by up to 40%, translating into measurable cycle-life improvement [60], [61]. Thermal stress, driven by semiconductor losses and uneven current sharing, further impacts reliability; interleaved and modular converter structures distribute thermal loading more evenly and improve fault tolerance in DC microgrid applications.

### 6.3. Comparative summary of converter topologies

Comparative evaluation of PV–HESS converter topologies typically consider efficiency range, component count, voltage gain capability, controllability, cost, and scalability. Non-isolated bidirectional

boost/buck–boost converters offer high efficiency and simplicity but limited voltage gain and no galvanic isolation; isolated dual-active-bridge (DAB) and full-bridge topologies provide wide voltage adaptability and soft switching at the expense of higher complexity and cost. MCs reduce redundant conversion stages and improve power density but require sophisticated control and protection schemes. Recent comparative reviews highlight that multiport and partially integrated architectures achieve superior system-level efficiency and reduced battery stress compared to cascaded dual-converter approaches [24], [62], [63]. Table 2 shows the comparison summarizing topology type, isolation capability, peak efficiency, control complexity, advantages, and limitations is recommended to clearly position state-of-the-art solutions and guide topology selection for specific PV–HESS applications.

Table 2. Comparative summary of converter topologies for PV–HESS

Topology type	Isolation capability	Reported peak efficiency	Control complexity	Advantages	Limitations
Passive hybrid (direct parallel)	No	>95% (no extra stage)	Very low	Minimal cost, no additional converter	Poor controllability, battery current ripple, limited lifetime improvement
Dual-converter (cascaded bidirectional DC–DC) MPC	Optional	92–96%	Moderate	Independent control of battery and SC, flexible EMS	Higher component count, multiple conversion stages
Isolated MC (transformer-based)	Yes	90–94.3% (reported prototypes) [64]	Moderate	Fewer switches, higher power density, reduced stages	No galvanic isolation, safety constraints
Integrated three-port converter (switching-capacitor/hybrid)	Partial/no	95–96% (soft-switching prototypes) [65]	High	Galvanic isolation, bidirectional power flow, soft switching	Higher cost, magnetic design complexity
Modular MC	Typically, isolated	Up to 94% [66]	Moderate–high	Reduced redundant stages, compact structure, improved reliability	More sophisticated modulation & protection
		~95% (reported lab-scale systems) [67]	High	Scalability, improved PV/battery utilization	Increased control coordination, higher design complexity

Recent reviews indicate that multiport and partially integrated architectures reduce redundant power conversion stages, improve system-level efficiency, and mitigate battery stress compared to cascaded dual-converter structures [66]. Isolated multiport designs further enhance safety and enable soft-switching operation, achieving peak efficiencies around 96% in experimental prototypes [65].

## 7. CONCLUSION

This review demonstrates that converter topology and control strategy are decisive factors in determining the efficiency, reliability, and lifetime performance of PV-based battery–SC HESS. Passive hybridization offers structural simplicity but limited controllability and modest battery stress mitigation, whereas active and fully controlled bidirectional converter architectures significantly suppress ripple current, improve dynamic response, and extend battery cycle life. Isolated topologies such as dual-active-bridge converters provide wide voltage adaptability and soft-switching capability for medium- to high-power applications, while non-isolated interleaved converters remain suitable for cost-sensitive and lower-voltage systems. Multiport and partially integrated architectures reduce redundant conversion stages and enhance power density, though at the expense of increased control complexity. Advanced energy management strategies—particularly optimization-based and model predictive approaches—further enhance degradation-aware dispatch and transient performance, marking a transition toward intelligent, data-driven hybrid storage control. Overall, the convergence of high-efficiency converter design, wide-bandgap semiconductor technology, modular architectures, and predictive control frameworks establishes a clear pathway toward scalable, high-performance PV–HESS deployment in future renewable microgrids and distributed energy systems.

## ACKNOWLEDGMENTS

The authors gratefully acknowledge Universitas Ahmad Dahlan (UAD), and the Embedded Systems and Power Electronics Research Group (ESPERG) for their invaluable support and contributions to this

research. The facilities, guidance, and collaborative environment provided by these institutions were instrumental in the successful completion and publication of this work.

### FUNDING INFORMATION

Authors state no funding involved.

### AUTHOR CONTRIBUTIONS STATEMENT

This journal uses the Contributor Roles Taxonomy (CRediT) to recognize individual author contributions, reduce authorship disputes, and facilitate collaboration.

Name of Author	C	M	So	Va	Fo	I	R	D	O	E	Vi	Su	P	Fu
Tole Sutikno	✓	✓		✓	✓	✓		✓	✓	✓		✓		✓
Hendril Satrian Purnama	✓	✓				✓		✓	✓	✓	✓		✓	
Auzani Jidin		✓				✓		✓		✓				

C : Conceptualization

M : Methodology

So : Software

Va : Validation

Fo : Formal analysis

I : Investigation

R : Resources

D : Data Curation

O : Writing - Original Draft

E : Writing - Review & Editing

Vi : Visualization

Su : Supervision

P : Project administration

Fu : Funding acquisition

### CONFLICT OF INTEREST STATEMENT

Author states there is no potential conflict of interest.

### DATA AVAILABILITY

Data availability is not applicable to this paper as no new data were created or analyzed in this study





### REFERENCES

- [1] I. Challouf *et al.*, "Hybrid Supercapacitor–Battery System for PV Modules Under Partial Shading: Modeling, Simulation, and Implementation," *Energies*, vol. 18, no. 23, 2025, doi: 10.3390/en18236110.
- [2] M. E. Şahin and F. Blaabjerg, "A Hybrid PV-Battery/Supercapacitor System and a Basic Active Power Control Proposal in MATLAB/Simulink," *Electronics*, vol. 9, no. 1, 2020, doi: 10.3390/electronics9010129.
- [3] D. Rekioua *et al.*, "Optimized Power Management Approach for Photovoltaic Systems with Hybrid Battery-Supercapacitor Storage," *Sustainability*, vol. 15, no. 19, 2023, doi: 10.3390/su151914066.
- [4] E. Hossain, H. M. R. Faruque, M. S. H. Sunny, N. Mohammad, and N. Nawar, "A Comprehensive Review on Energy Storage Systems: Types, Comparison, Current Scenario, Applications, Barriers, and Potential Solutions, Policies, and Future Prospects," *Energies*, vol. 13, no. 14, 2020, doi: 10.3390/en13143651.
- [5] Q. Hassan, M. Jaszczur, A. M. Abdulateef, J. Abdulateef, A. Hasan, and A. Mohamad, "An analysis of photovoltaic/supercapacitor energy system for improving self-consumption and self-sufficiency," *Energy Reports*, vol. 8, pp. 680–695, 2022, doi: 10.1016/j.egy.2021.12.021.
- [6] A. Monthly *et al.*, "Battery Supercapacitor Hybrid Storage System," *International Journal of Innovative Research in Science Engineering and Technology (IJIRSET)*, vol. 14, no. 4, 2025, doi: 10.15680/IJIRSET.2025.1404260.
- [7] C. V. M. Gopi and R. Ramesh, "Review of battery-supercapacitor hybrid energy storage systems for electric vehicles," *Results in Engineering*, vol. 24, p. 103598, 2024, doi: 10.1016/j.rineng.2024.103598.
- [8] J. M. Guerrero, M. Chandorkar, T.-L. Lee, and P. C. Loh, "Advanced control architectures for intelligent microgrids—Part I: Decentralized and hierarchical control," *IEEE Transactions on Industrial Electronics*, vol. 60, no. 4, pp. 1254–1262, 2012, doi: 10.1109/TIE.2012.2194969.
- [9] A. Etxeberria, I. Vechiu, H. Camblong, and J.-M. Vinassa, "Comparison of three topologies and controls of a hybrid energy storage system for microgrids," *Energy Conversion and Management*, vol. 54, no. 1, pp. 113–121, 2012, doi: 10.1016/j.enconman.2011.10.012.
- [10] F. Blaabjerg, Y. Yang, D. Yang, and X. Wang, "Distributed power-generation systems and protection," in *Proceedings of the IEEE*, vol. 105, no. 7, pp. 1311–1331, 2017, doi: 10.1109/JPROC.2017.2696878.
- [11] R. H. Lasseter, "Microgrids," in *2002 IEEE Power Engineering Society Winter Meeting Conference Proceedings (Cat. No. 02CH37309)*, 2002, pp. 305–308.
- [12] A. K. Bhattacharjee, N. Kutkut, and I. Batarseh, "Review of multiport converters for solar and energy storage integration," *IEEE Transactions on Power Electronics*, vol. 34, no. 2, pp. 1431–1445, 2018, doi: 10.1109/TPEL.2018.2830788.
- [13] J. S. Menye, M.-B. Camara, and B. Dakyo, "Lithium Battery Degradation and Failure Mechanisms: A State-of-the-Art Review," *Energies*, vol. 18, no. 2, 2025, doi: 10.3390/en18020342.
- [14] X. Han *et al.*, "A review on the key issues of the lithium ion battery degradation among the whole life cycle," *eTransportation*, vol. 1, p. 100005, 2019, doi: 10.1016/j.etrans.2019.100005.
- [15] T. Li, X.-Z. Yuan, L. Zhang, D. Song, K. Shi, and C. Bock, "Degradation Mechanisms and Mitigation Strategies of Nickel-Rich





- NMC-Based Lithium-Ion Batteries,” *Electrochemical Energy Reviews*, vol. 3, no. 1, pp. 43–80, 2020, doi: 10.1007/s41918-019-00053-3.
- [16] T. Sutikno, W. Arsadiando, N. S. Widodo, B. Santosa, and H. M. Jopri, “Comprehensive Analysis of Current Research Trends in Battery Technologies as Electricity Storage Devices for Electric Bikes: A Review,” *Journal of Electrical and Electronics Engineering*, vol. 15, no. 2, pp. 138–143, 2022.
- [17] M. Khalid, “A review on the selected applications of battery-supercapacitor hybrid energy storage systems for microgrids,” *Energies*, vol. 12, no. 23, 2019, doi: 10.3390/en12234559.
- [18] L. Kouchachvili, W. Yaïci, and E. Entchev, “Hybrid battery/supercapacitor energy storage system for the electric vehicles,” *Journal of Power Sources*, vol. 374, pp. 237–248, 2018, doi: 10.1016/j.jpowsour.2017.11.040.
- [19] F. Naseri, S. Karimi, E. Farjah, and E. Schaltz, “Supercapacitor management system: A comprehensive review of modeling, estimation, balancing, and protection techniques,” *Renewable and Sustainable Energy Reviews*, vol. 155, 2022, doi: 10.1016/j.rser.2021.111913.
- [20] Y.-W. Lee *et al.*, “A pseudo-capacitive chalcogenide-based electrode with dense 1-dimensional nanoarrays for enhanced energy density in asymmetric supercapacitors,” *arXiv preprint*, 2019, doi: 10.48550/arXiv.1905.06039.
- [21] S. Bellani *et al.*, “Scalable Production of Graphene Inks via Wet-Jet Milling Exfoliation for Screen-Printed Micro-Supercapacitors,” *Advanced Functional Materials*, vol. 29, no. 14, Feb. 2019, doi: 10.1002/adfm.201807659.
- [22] H. Yu, F. Castelli-Dezza, F. Cheli, X. Tang, X. Hu, and X. Lin, “Dimensioning and Power Management of Hybrid Energy Storage Systems for Electric Vehicles With Multiple Optimization Criteria,” *IEEE Transactions on Power Electronics*, vol. 36, no. 5, pp. 5545–5556, May 2021, doi: 10.1109/tpe.2020.3030822.
- [23] Y. Tong, I. Salhi, Q. Wang, G. Lu, and S. Wu, “Bidirectional DC-DC Converter Topologies for Hybrid Energy Storage Systems in Electric Vehicles: A Comprehensive Review,” *Energies*, vol. 18, no. 9, p. 2312, 2025, doi: 10.3390/en18092312.
- [24] M. J. Lencwe, T. O. Olwal, S. P. D. Chowdhury, and M. Sibanyoni, “Nonsolitary two-way DC-to-DC converters for hybrid battery and supercapacitor energy storage systems: A comprehensive survey,” *Energy Reports*, vol. 11, pp. 2737–2767, 2024, doi: 10.1016/j.egy.2024.02.024.
- [25] A. S. Kamaraja, M. Karuppusampandiyana, and K. K. Kumar, “Enhancing electric vehicle battery charging efficiency through advanced DC to DC conversion in solar PV-integrated PRHGHECIC for improved energy storage,” *Journal of Energy Storage*, vol. 99, 2024, doi: 10.1016/j.est.2024.113247.
- [26] T. Sutikno, H. S. Purnama, N. S. Widodo, S. Padmanaban, and M. R. Sahid, “A review on non-isolated low-power DC–DC converter topologies with high output gain for solar photovoltaic system applications,” *Clean Energy*, vol. 6, no. 4, pp. 557–572, Aug. 2022, doi: 10.1093/ce/zkac037.
- [27] X. Fan, H. Sun, Z. Yuan, Z. Li, R. Shi, and N. Ghadimi, “High Voltage Gain DC/DC Converter Using Coupled Inductor and VM Techniques,” *IEEE Access*, vol. 8, pp. 131975–131987, 2020, doi: 10.1109/ACCESS.2020.3002902.
- [28] J. C. Hernández, F. Sanchez-Sutil, and F. J. Muñoz-Rodríguez, “Design criteria for the optimal sizing of a hybrid energy storage system in PV household-prosumers to maximize self-consumption and self-sufficiency,” *Energy*, vol. 186, 2019, doi: 10.1016/j.energy.2019.07.157.
- [29] T. Rout, A. Chowdhury, M. K. Maharana, and S. Samal, “Analysis of energy management system for photovoltaic system with battery and supercapacitor using fuzzy logic controller,” in *2018 Technologies for Smart-City Energy Security and Power (ICSESP), Bhubaneswar, India*, 2018, pp. 1–4, doi: 10.1109/ICSESP.2018.8376737.
- [30] D. Ruiz-Robles, X. Alcibar-Martinez, T. Sandoval-Valencia, J. A. Franco, and Q. Hernandez-Escobedo, “High-Gain bidirectional isolated DC-DC converter for PV-BESS systems using a 10 kHz ferrite-core transformer: design, simulation, and experimental validation,” *Results in Engineering*, vol. 28, p. 108078, 2025, doi: 10.1016/j.rineng.2025.108078.
- [31] K. M. Nagabushanam, T. Mahto, S. V. Tewari, and R. R. Udumula, “High gain Bi-directional KY converter for low power EV applications,” *Energy*, vol. 313, p. 133718, 2024, doi: 10.1016/j.energy.2024.133718.
- [32] T. Sutikno, R. A. Aprilianto, and H. S. Purnama, “Application of non-isolated bidirectional DC-DC converters for renewable and sustainable energy systems: A review,” *Clean Energy*, vol. 7, no. 2, pp. 293–311, 2023, doi: 10.1093/ce/zkac070.
- [33] Z. Yan, J. Zeng, Z. Guo, R. Hu, and J. Liu, “A Soft-Switching Bidirectional DC-DC Converter with High Voltage Gain and Low Voltage Stress for Energy Storage Systems,” *IEEE Transactions on Industrial Electronics*, vol. 68, no. 8, pp. 6871–6880, 2021, doi: 10.1109/TIE.2020.3005100.
- [34] M. Vijayan, R. R. Udumula, T. Mahto, and R. E. K.M., “A novel multi-port high-gain bidirectional DC–DC converter for energy storage system integration with DC microgrids,” *Journal of Energy Storage*, vol. 87, p. 111431, 2024, doi: 10.1016/j.est.2024.111431.
- [35] T. Sutikno, H. S. Purnama, R. A. Aprilianto, A. Jusoh, N. S. Widodo, and B. Santosa, “Modernisation of DC-DC converter topologies for solar energy harvesting applications: A review,” *Indonesian Journal of Electrical Engineering and Computer Science*, vol. 28, no. 3, pp. 1845–1872, 2022, doi: 10.11591/ijeecs.v28.i3.pp1845-1872.
- [36] K. Sayed, S. Abdel-Khalek, H. M. H. Zakaly, and M. Aref, “Energy Management and Control in Multiple Storage Energy Units (Battery–Supercapacitor) of Fuel Cell Electric Vehicles,” *Materials*, vol. 15, no. 24, pp. 1–19, 2022, doi: 10.3390/ma15248932.
- [37] S. Neelagiri and P. Usha, “Advanced multi-source converters for DC microgrids: integrating photovoltaic, wind, and hybrid storage systems,” *International Journal of Power Electronics and Drive Systems*, vol. 16, no. 2, pp. 1261–1273, 2025, doi: 10.11591/ijpeds.v16.i2.pp1261-1273.
- [38] M. I. Ullah, J. Forslund, J. S. Döhler, and I. Temiz, “Power quality assessment of a wave energy converter using energy storage,” in *Proceedings of the European Wave and Tidal Energy Conference*, vol. 8, no. 1, pp. 57–63, 2023, doi: 10.36688/ewtec-2023-315.
- [39] W. Zhang and J. Yang, “The Impact of Hybrid Energy Storage System on the Battery Cycle Life of Replaceable Battery Electric Vehicle,” *World Electric Vehicle Journal*, vol. 14, no. 9, 2023, doi: 10.3390/wevj14090248.
- [40] I. Jarraya, F. Abdelhedi, and N. Rizoug, “An Innovative Power Management Strategy for Hybrid Battery–Supercapacitor Systems in Electric Vehicle,” *Mathematics*, vol. 12, no. 1, 2024, doi: 10.3390/math12010050.
- [41] W. Yang, S. Wang, Y. Zhu, D. Xu, and T. Pan, “Model predictive control of Hybrid Energy Storage Systems based on Dynamic Mode Decomposition,” *Journal of Energy Storage*, vol. 148, p. 120210, 2026, doi: 10.1016/j.est.2025.120210.
- [42] M. Z. Bhayo, Y. Han, K. Bhagat, J. Hussain, A. N. Sanjrani, and A. Narejo, “Advanced dynamic power management using model predictive control in DC microgrids with hybrid storage and renewable energy sources,” *Journal of Energy Storage*, vol. 106, p. 114830, 2025, doi: 10.1016/j.est.2024.114830.
- [43] Y.-E. Wu and P.-N. Chiu, “A High-Efficiency Isolated-Type Three-Port Bidirectional DC/DC Converter for Photovoltaic Systems,” *Energies*, vol. 10, no. 4, p. 434, 2017, doi: 10.3390/en10040434.
- [44] S. Mukherjee, D. Mukherjee, and D. Kastha, “Multiport Soft-Switching Bidirectional DC-DC Converter for Hybrid Energy

- Storage Systems,” in *2019 IEEE Applied Power Electronics Conference and Exposition (APEC)*, 2019, pp. 2103–2109, doi: 10.1109/APEC.2019.8722270.
- [45] S. Hasanpour, M. Forouzesh, Y. P. Siwakoti, and F. Blaabjerg, “A Novel Full Soft-Switching High-Gain DC/DC Converter Based on Three-Winding Coupled-Inductor,” *IEEE Transactions on Power Electronics*, vol. 36, no. 11, pp. 12656–12669, 2021, doi: 10.1109/TPEL.2021.3075724.
- [46] S. M. Hashemzadeh and B. Zhu, “A multi-port high step-up converter integrating coupled inductor and high-frequency transformer with hybrid isolated/non-isolated outputs for renewable energy-based DC micro grids,” *Energy*, vol. 335, p. 138350, 2025, doi: 10.1016/j.energy.2025.138350.
- [47] S. M. Malik, Y. Sun, and J. Hu, “An adaptive virtual capacitive droop for hybrid energy storage system in DC microgrid,” *Journal of Energy Storage*, vol. 70, p. 107809, 2023, doi: 10.1016/j.est.2023.107809.
- [48] Z. Zhang, F. Lin, Z. Yang, X. Fang, H. Sun, and X. Lu, “Improved adaptive droop control for energy storage systems in independent distributed controlled DC microgrid based on dynamic diffusion algorithm,” *Electric Power Systems Research*, vol. 248, p. 111896, 2025, doi: 10.1016/j.epsr.2025.111896.
- [49] B. Sedhom, E. Badran, I. Mansy, and O. Elfadawy, “A Secondary Adaptive Droop Controller for Voltage/Frequency Restoration , and Active/Reactive Power Sharing for Hybrid AC/DC Smart Microgrids,” *Research Square Pre-print*, pp. 0–40, 2024, doi: 10.21203/rs.3.rs-5291458/v1.
- [50] E. Farrokhi, H. Ghoreishy, and R. A. Ahangar, “Optimization-based power management for battery/supercapacitor hybrid energy storage system with load estimation capability in a DC microgrid,” *International Journal of Electrical Power & Energy Systems*, vol. 155, p. 109665, 2024, doi: 10.1016/j.ijepes.2023.109665.
- [51] L. Barelli, D.-A. Ciupageanu, A. Ottaviano, D. Pelosi, and G. Lazaroiu, “Stochastic power management strategy for hybrid energy storage systems to enhance large scale wind energy integration,” *Journal of Energy Storage*, vol. 31, p. 101650, 2020, doi: 10.1016/j.est.2020.101650.
- [52] M. I. Saleem, S. Saha, U. Izhar, and L. Ang, “A stochastic MPC-based energy management system for integrating solar PV, battery storage, and EV charging in residential complexes,” *Energy and Buildings*, vol. 325, p. 114993, 2024, doi: 10.1016/j.enbuild.2024.114993.
- [53] X. Wang, Q. Hua, P. Liu, and L. Sun, “Stochastic dynamic programming based optimal energy scheduling for a hybrid fuel cell/PV/battery system under uncertainty,” *Process Safety and Environmental Protection*, vol. 165, pp. 380–386, 2022, doi: 10.1016/j.psep.2022.07.025.
- [54] J. Xu *et al.*, “Model Predictive Control for the Reduction of DC-link Current Ripple in Two-level Three-phase Voltage Source Inverters,” in *2020 22nd European Conference on Power Electronics and Applications (EPE'20 ECCE Europe)*, United States: IEEE, 2020, p. P.1–P.9, doi: 10.23919/EPE20ECCEEurope43536.2020.9215838.
- [55] C. Zhang, Y. Zheng, W. Zhu, and R. Gao, “Model Predictive Current Control for DC-Link Ripple Voltage Suppression in Electrolytic Capacitor-Less Drive System,” *Energies*, vol. 15, no. 24, p. 9297, 2022, doi: 10.3390/en15249297.
- [56] Q. Guo, I. Bahri, D. Diallo, and E. Berthelot, “Model predictive control and linear control of DC–DC boost converter in low voltage DC microgrid: An experimental comparative study,” *Control Engineering Practice*, vol. 131, p. 105387, 2023, doi: 10.1016/j.conengprac.2022.105387.
- [57] K. A. Severson *et al.*, “Data-driven prediction of battery cycle life before capacity degradation,” *Nature Energy*, vol. 4, no. 5, pp. 383–391, 2019, doi: 10.1038/s41560-019-0356-8.
- [58] T. Zhang and G. Strbac, “Artificial Intelligence Applications for Energy Storage: A Comprehensive Review,” *Energies*, vol. 18, no. 17, p. 4718, 2025, doi: 10.3390/en18174718.
- [59] M. S. Campobasso, A. Castorrini, A. Ortolani, and E. Minisci, “Probabilistic analysis of wind turbine performance degradation due to blade erosion accounting for uncertainty of damage geometry,” *Renewable and Sustainable Energy Reviews*, vol. 178, p. 113254, 2023, doi: 10.1016/j.rser.2023.113254.
- [60] D. Marrero-López, R. Romero, F. Martín, and J. R. Ramos-Barrado, “Effect of the deposition temperature on the electrochemical properties of La<sub>0.6</sub>Sr<sub>0.4</sub>Co<sub>0.8</sub>Fe<sub>0.2</sub>O<sub>3-δ</sub> cathode prepared by conventional spray-pyrolysis,” *Journal of Power Sources*, vol. 255, pp. 308–317, 2014, doi: 10.1016/j.jpowsour.2014.01.021.
- [61] M. Orosz, Q. Altes-Buch, A. Mueller, and V. Lemort, “Experimental validation of an electrical and thermal energy demand model for rapid assessment of rural health centers in sub-Saharan Africa,” *Applied Energy*, vol. 218, pp. 382–390, 2018, doi: 10.1016/j.apenergy.2018.03.004.
- [62] S. Farajdadian, A. Hajizadeh, and M. Soltani, “Recent developments of multiport DC/DC converter topologies, control strategies, and applications: A comparative review and analysis,” *Energy Reports*, vol. 11, pp. 1019–1052, 2024, doi: 10.1016/j.egyr.2023.12.054.
- [63] L. Gevorkov, J. L. Domínguez-García, L. T. Romero, and À. F. Martínez, “Modern MultiPort Converter Technologies: A Systematic Review,” *Applied Sciences*, vol. 13, no. 4, p. 2579, 2023, doi: 10.3390/app13042579.
- [64] J. Narayanaswamy and S. Mandava, “Non-Isolated Multiport Converter for Renewable Energy Sources: A Comprehensive Review,” *Energies*, vol. 16, no. 4, p. 1834, 2023, doi: 10.3390/en16041834.
- [65] M. K. Klidbari, N. Souiri, Z. S. Habibolah, and H. Montazeri Hedeshi, “A Hybrid Three-Port Topology for Urban Charging Stations,” in *Conference Proceedings - IEEE Applied Power Electronics Conference and Exposition - APEC*, pp. 2202–2206, 2025, doi: 10.1109/APEC48143.2025.10977273.
- [66] P. Xu *et al.*, “Nonisolated switching-capacitor-integrated three- port converters with seamless PWM/PFM modulation,” *Solar Energy*, vol. 224, pp. 160–174, 2021, doi: 10.1016/j.solener.2021.04.023.
- [67] A. M. Fares, C. Klumpner, and M. Summer, “A Novel Modular Multiport Converter for Enhancing the Performance of Photovoltaic-Battery Based Power Systems,” *Applied Sciences*, vol. 9, no. 19, p. 3948, 2019, doi: 10.3390/app9193948.





**BIOGRAPHIES OF AUTHORS**

**Prof. Ir. Tole Sutikno, Ph.D., MIET, IPM., ASEAN Eng.**     is a full professor in the Department of Electrical Engineering at Universitas Ahmad Dahlan (UAD) in Yogyakarta, Indonesia. He has held this position since 2023, having previously served as an associate professor from 2008. He earned his bachelor's degree from Universitas Diponegoro in 1999, his master's degree from Universitas Gadjah Mada in 2004, and his Ph.D. in Electrical Engineering from Universiti Teknologi Malaysia in 2016, where his doctoral research focused on advanced digital power electronics and intelligent control systems. From 2016 to 2021, he served as the Director of the Institute for Scientific Publishing and Publications (LPPI) at UAD, where he led initiatives to strengthen research visibility, journal management, and international collaboration in scholarly publishing. Since 2024, he has served as the head of the master's program in electrical engineering at UAD, following his leadership of the undergraduate program in electrical engineering in 2022. He is also the founding leader of the Embedded Systems and Power Electronics Research Group (ESPERG), which actively collaborates with both national and international institutions on topics such as fault-tolerant embedded systems, FPGA-based control, and renewable energy integration. He is widely acknowledged for his contributions to digital design, industrial electronics, motor drives, robotics, intelligent systems, and AI-based automation. His interdisciplinary research emphasises practical deployments in industrial and healthcare contexts, covering FPGA applications, embedded systems, power electronics, and digital libraries. He has published 380 peer-reviewed articles in high-impact journals and conferences indexed by Scopus. As of 2025, Google Scholar indicates over 6,000 citations, with an h-index of 36 and an i10-index of 174. In recognition of his global research impact, he has been listed among the Top 2% of Scientists Worldwide by Stanford University and Elsevier BV from 2021 to the present, a distinction based on standardised citation metrics across all scientific disciplines. He can be contacted at email: [tole@te.uad.ac.id](mailto:tole@te.uad.ac.id).



**Hendril Satrian Purnama**     received his B.Eng. degree in Electrical Engineering from Universitas Ahmad Dahlan, Yogyakarta, Indonesia in 2017. After receiving his degree, he became a member of the Embedded Systems and Power Electronics Research Group (ESPERG), and worked there as a researcher. In addition, he is also active as assistant editor in several international journals in the field of electrical engineering, computer and informatics. His research interests include power electronics, renewable energy technology, robotics and the internet of things. He can be contacted at email: [lfriyan220@gmail.com](mailto:lfriyan220@gmail.com).



**Auzani Jidin**     received the B.Eng., M.Eng., and Ph.D. degrees in power electronics and drives from Universiti Teknologi Malaysia (UTM), Malaysia, in 2002, 2004, and 2011, respectively. He is currently a Lecturer with the Department of Power Electronics and Drives, Faculty of Electrical Engineering, Universiti Teknikal Malaysia Melaka (UTeM), Malaysia. His research interests include the field of power electronics, motor drive systems, FPGA, and DSP applications. He can be contacted at email: [syahruhisham@utem.edu.my](mailto:syahruhisham@utem.edu.my).