

High-efficiency buck–boost inverter architecture for transformer-less solar photovoltaic grid integration

CH. Saikiran , Jangam Kishore Babu , Kalagotla Chenchireddy , G. Sriharsha , CH. Nikhil Prasad 

Department of Electrical and Electronics Engineering, Geethanjali College of Engineering and Technology, Telangana, India

Article Info

Article history:

Received Nov 16, 2025

Revised Mar 13, 2026

Accepted May 12, 2026

Keywords:

Buck-boost inverter

Grid integration

Leakage current reduction

Maximum power point tracking

Solar photovoltaic

ABSTRACT

A buck-boost transformerless inverter provides an efficient and compact way to connect solar photovoltaic (PV) systems to the utility grid. By removing the large line-frequency transformer, the inverter becomes smaller, cheaper, and more efficient at converting energy. The buck-boost feature allows the system to handle a wide range of PV input voltages while keeping a stable AC output. This ensures reliable performance even with changing sunlight conditions. It uses advanced modulation methods and techniques to reduce leakage currents and meet safety standards for transformerless PV systems. The inverter allows for two-way power flow, improves maximum power point tracking (MPPT), and ensures smooth grid synchronization for better energy production. Its simple power stage and control design make it appropriate for both residential and commercial PV setups. Overall, the buck-boost transformerless inverter improves the performance, safety, and grid compatibility of modern PV systems.

This is an open access article under the [CC BY-SA](https://creativecommons.org/licenses/by-sa/4.0/) license.



Corresponding Author:

CH. Saikiran

Department of Electrical and Electronics Engineering, Geethanjali College of Engineering and Technology

Keesara Mandal, Hyderabad 501301, Telangana, India

Email: 23r15a0207@gcet.edu.in

1. INTRODUCTION

The swift global growth of photovoltaic (PV) systems has led to an increasing demand for high-efficiency, reliable, and inexpensive grid-connected power converter systems. Due to environmental issues, falling PV module prices, and favorable energy policies, solar has become one of the most widely deployed forms of renewable energy technology in the world [1]-[4]. However, the output from PV systems is fundamentally variable direct current (DC) in nature and is dependent on solar irradiance, the operating temperature, and partial shading. Therefore, it is critical to implement durable power conversion devices capable of regulating DC output voltages, achieving the maximum available power output, and providing AC output that meets current international power quality standards when connected to an electric grid [2], [5]-[8].

Traditional grid-tied inverters making use of either line-frequency or high-frequency transformers are generally employed to provide galvanic isolation and to provide appropriate voltage transformation ratios for integration into the grid. While these transformers have benefits, they significantly contribute to the weight, cost, footprint, and conduction losses of the system, ultimately decreasing overall efficiency [3], [9]-[12]. To combat these issues, transformerless topology-based inverters have arisen as a viable choice for integration to the grid, providing high output conversion efficiency, compact size, and competitive bill of materials costs. These features have established transformerless inverters as a standard solution for modern residential and commercial PV systems [4]. However, the absence of galvanic isolation creates its own challenges, one being the phenomenon of leakage current between the PV array.

2. BUCK BOOST TRANSFORMERLESS INVERTER FOR SOLAR PV GRID INTEGRATION

This block diagram represents the overall working of the buck-boost transformer less inverter system for solar PV grid integration. The PV array acts as the primary energy source, converting sunlight into DC power. This DC voltage is fed to the DC-DC buck-boost converter, which adjusts the voltage level — stepping it up (boost) or stepping it down (buck) — depending on the solar input. The converter uses switches (S1, S2), an inductor (L), and a diode (D) to perform this regulation. The output from this stage is stored and stabilized by the DC link capacitor, which ensures a constant DC voltage for the next stage. The inverter section (S3, S4, S5) then converts the regulated DC voltage into AC using pulse width modulation (PWM) signals provided by the control unit. The control block, which combines maximum power point tracking (MPPT) and PWM control, ensures optimal power extraction from the PV array and proper switching operation. Finally, the AC output is passed through a grid filter (Lg) to remove harmonics before being supplied to the utility grid, ensuring smooth, high-quality power delivery. Also illustrates the operation of a solar PV-based buck-boost transformer less inverter connected to the utility grid. The PV array generates DC power, which is processed by the DC-DC buck-boost converter to regulate voltage levels under varying sunlight conditions. The DC link capacitor smoothes this voltage and supplies it to the inverter, which converts DC into grid-compatible AC power. The control unit, consisting of MPPT and PWM, optimizes power extraction and controls switching operations. The grid filter (Lg) removes unwanted harmonics, ensuring a clean sinusoidal waveform before feeding the power efficiently into the utility grid [13]-[18].

Figure 1 presents the modulation strategy and switching operation of the proposed buck-boost transformer-less inverter (BBTI). The figure illustrates the gate signal generation circuit together with the switching states and operating modes during positive and negative half cycles used for inverter operation.

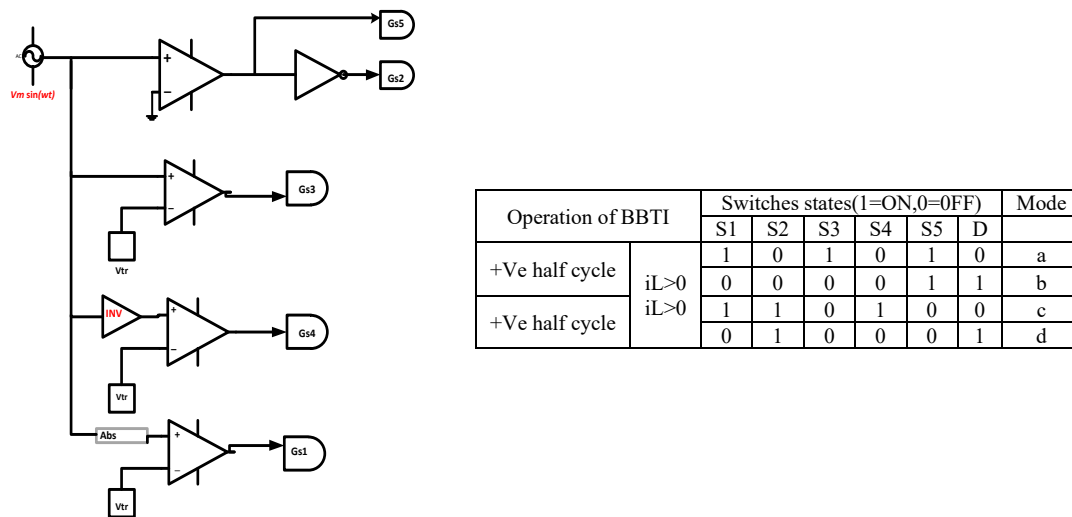

Figure 1. The proposed modulation strategy of the BBTI topology

PV array (PV+CPV) – this is the solar panel setup that captures sunlight and turns it into DC electricity. DC-DC buck-boost converter (S1, S2, L, D) – this section adjusts the voltage from the PV array, either stepping it up or down, to keep it at an optimal level. DC link capacitor – think of this as a storage buffer. It smoothes out voltage fluctuations so that the power is stable before moving forward. Control (MPPT+PWM): MPPT ensures the panels always work at their most efficient point, regardless of sunlight conditions. PWM controls the switching of converters and inverters to regulate the flow of energy. Inverter (S3, S4, S5) – converts the DC electricity into AC, since our homes and grids run on AC power. Grid filter (Lg) – cleans up the AC electricity (removes noise or harmonics) before sending it to the grid. Utility grid – the final destination where the clean, regulated solar power is supplied for use in homes, and industries.

3. RESULTS AND DISCUSSION

In this section, the MATLAB/Simulation results are presented, the simulation results waveforms and hardware circuit diagram and output waveform presented. The objective of this paper is to provide good quality of power by using buck boost transformerless inverter for solar PV grid integration.

3.1. Simulation results

Figure 2 shows the MATLAB/Simulink model developed for validating the proposed BBTI architecture. The simulation model is used to evaluate the PV system performance and grid integration capability. Figure 3 presents the simulation output waveforms of the proposed BBTI. Figure 3 shows the grid voltage, grid current, and auxiliary capacitor voltage waveforms obtained from the simulation results to verify the performance of the proposed system.

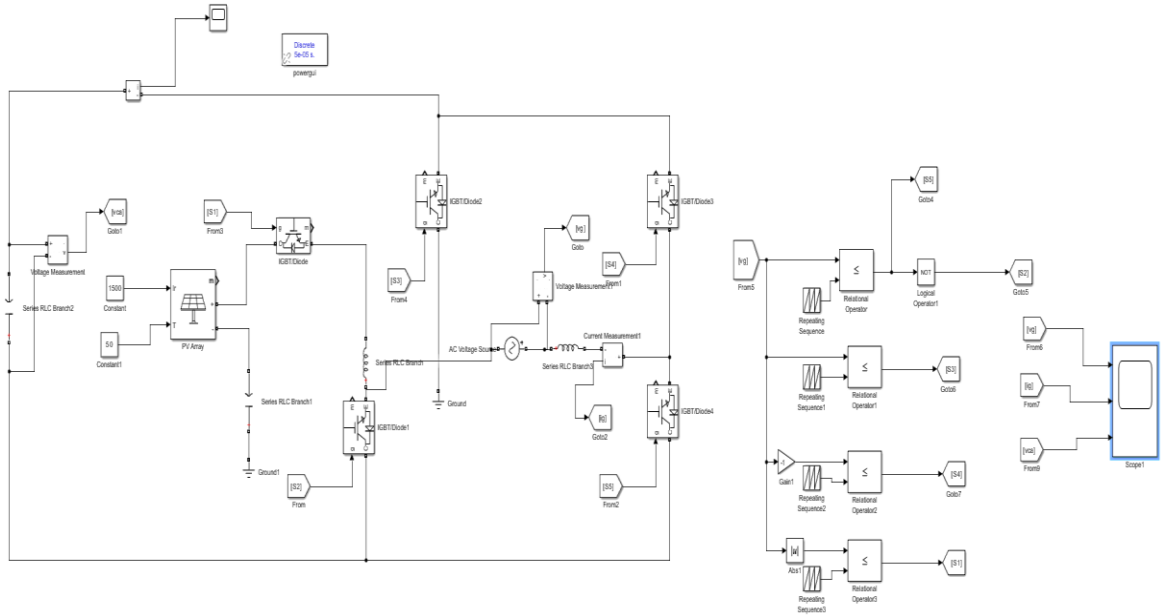

Figure 2. MATLAB/Simulink model of the proposed BBTI system

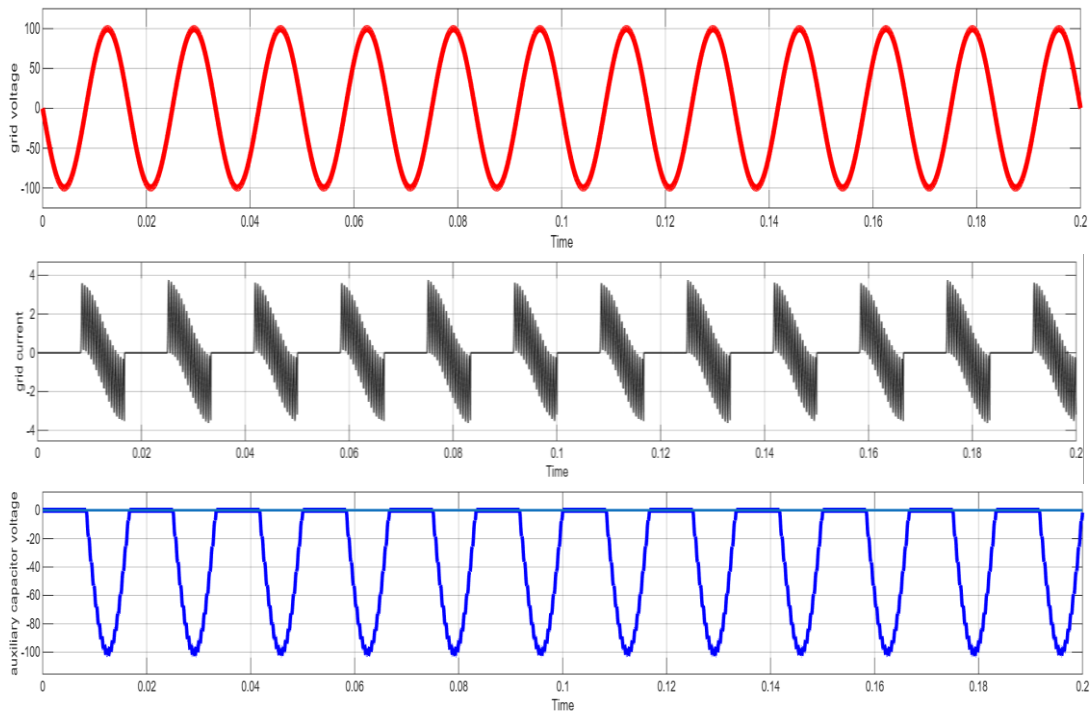

Figure 3. Simulation output waveforms of the proposed BBTI system

4. CONCLUSION

This paper presents a comprehensive analysis and simulation of a BBTI architecture for single-phase solar PV grid integration. The proposed topology effectively addresses the core challenges of transformer-less inverters, specifically leakage current and limited voltage operation range. By employing a single-stage design with a common ground connection between the PV source and the grid neutral, the system effectively suppresses leakage currents, enhancing safety and reliability. A key advantage of this BBTI is its buck-boost capability, which enables it to handle a wide range of PV input voltages while maintaining MPPT. The use of a single energy storage inductor simplifies the design and ensures symmetrical operation during both positive and negative grid half-cycles. The control scheme, which uses a simple sine-triangle PWM, ensures precise control and allows for the injection of a low-total harmonic distortion (THD) sinusoidal current into the grid. Simulation results confirm the inverter's robust performance, demonstrating high efficiency and a THD below the 3–5% range, which complies with IEEE-519 grid standards. The architecture's design with only five switches, with two operating at line frequency, significantly minimizes switching losses and enhances overall system efficiency. This makes the BBTI a viable and improved alternative to conventional full-bridge and two-stage inverter topologies. In conclusion, the proposed BBTI topology is a compact, cost-effective, and highly efficient solution for modern solar PV applications. Its ability to operate over a wide voltage range, suppress leakage currents, and maintain high power quality makes it well-suited for a variety of residential and small-scale grid-connected PV systems. Future work could explore the integration of advanced control algorithms to further optimize its performance under various grid conditions.

REFERENCES

- [1] S. Murlidharan, V. Ravulakole, J. Karnati, and H. Malik, "Battery Management System: Threat Modeling, Vulnerability Analysis, and Cybersecurity Strategy," *IEEE Access*, vol. 13, pp. 37198–37220, 2025, doi: 10.1109/ACCESS.2025.3543249.
- [2] K. Mansiri, S. Sukchai, and C. Sirisamphanwong, "Fuzzy Control Algorithm for Battery Storage and Demand Side Power Management for Economic Operation of the Smart Grid System at Naresuan University, Thailand," *IEEE Access*, vol. 6, pp. 32440–32449, 2018, doi: 10.1109/ACCESS.2018.2838581.
- [3] Y. Khawaja *et al.*, "Battery management solutions for li-ion batteries based on artificial intelligence," *Ain Shams Engineering Journal*, vol. 14, no. 12, 2023, doi: 10.1016/j.asej.2023.102213.
- [4] M. A. Rodriguez-Otero and E. O'Neill-Carrillo, "Efficient home appliances for a future DC residence," in *2008 IEEE Energy 2030 Conference*, 2008, doi: 10.1109/ENERGY.2008.4781006.
- [5] R. Hidalgo-Leon *et al.*, "A survey of battery energy storage system (BESS), applications and environmental impacts in power systems," in *2017 IEEE Second Ecuador Technical Chapters Meeting (ETCM)*, Salinas, Ecuador: IEEE, 2017, pp. 1–6, doi: 10.1109/ETCM.2017.8247485.
- [6] M. A. Hannan, M. M. Hoque, A. Mohamed, and A. Ayob, "Review of energy storage systems for electric vehicle applications: Issues and challenges," *Renewable and Sustainable Energy Reviews*, vol. 69, pp. 771–789, 2017, doi: 10.1016/j.rser.2016.11.171.
- [7] Y. Wang and Z. Chen, "A framework for state-of-charge and remaining discharge time prediction using unscented particle filter," *Applied Energy*, vol. 260, 2020, doi: 10.1016/j.apenergy.2019.114324.
- [8] P. J. Hall and E. J. Bain, "Energy-storage technologies and electricity generation," *Energy Policy*, vol. 36, no. 12, pp. 4352–4355, 2008.
- [9] M. F. Niri, T. M. N. Bui, T. Q. Dinh, E. Hosseinzadeh, T. F. Yu, and J. Marco, "Remaining energy estimation for lithium-ion batteries via Gaussian mixture and Markov models for future load prediction," *Journal of Energy Storage*, vol. 28, 2020, doi: 10.1016/j.est.2020.101271.
- [10] H. S. Ramadan, M. Becherif, and F. Claude, "Energy Management Improvement of Hybrid Electric Vehicles via Combined GPS/Rule-Based Methodology," *IEEE Transactions on Automation Science and Engineering*, vol. 14, no. 2, pp. 586–597, 2017, doi: 10.1109/TASE.2017.2650146.
- [11] X. Hu, J. Jiang, B. Egardt, and D. Cao, "Advanced Power-Source Integration in Hybrid Electric Vehicles: Multicriteria Optimization Approach," *IEEE Transactions on Industrial Electronics*, vol. 62, no. 12, pp. 7847–7858, 2015, doi: 10.1109/TIE.2015.2463770.
- [12] P. Weldon, P. Morrissey, and M. O'Mahony, "Long-term cost of ownership comparative analysis between electric vehicles and internal combustion engine vehicles," *Sustainable Cities and Society*, vol. 39, pp. 578–591, 2018, doi: 10.1016/j.scs.2018.02.024.
- [13] P. K. Chamathi, M. S. El Moursi, V. Khadkikar, K. H. Al Hosani, A. Al-Durra, and T. H. M. El-Fouly, "A Single Stage Doubly Grounded Transformerless Inverter Topology With Buck-Boost Voltage Capability for Grid Connected PV Systems," *IEEE Transactions on Power Delivery*, vol. 37, no. 6, pp. 5044–5058, 2022, doi: 10.1109/TPWRD.2022.3166506.
- [14] S. Dutta and K. Chatterjee, "A coupled inductor-based buck-boost type grid connected transformerless PV inverter having the ability to control two subarrays simultaneously," *IEEE Transactions on Industrial Electronics*, vol. 67, no. 7, pp. 5543–5553, 2020, doi: 10.1109/TIE.2019.2931512.
- [15] D. Debnath and K. Chatterjee, "Neutral point clamped transformerless grid connected inverter having voltage buck-boost capability for solar photovoltaic systems," *IET Power Electronics*, vol. 9, no. 2, pp. 385–392, 2016, doi: 10.1049/iet-pel.2014.0873.
- [16] B. Ramesh, K. Chenchireddy, K. Naveen, Y. Sneha, K. Saiprem, and M. Jameel, "A cutting-edge single-stage buck-boost transformer-less inverter for 1- ϕ grid-tied solar PV schemes," in *MATEC Web of Conferences*, vol. 392, 2024, doi: 10.1051/mateconf/202439201068.
- [17] S. A. Zaid, H. S. Samkari, and M. F. Allehyani, "Three-Phase Transformerless Buck-Inverter Topologies for PV Grid-Tied Systems: A Review," *Processes*, vol. 13, no. 11, 2025, doi: 10.3390/pr13113667.
- [18] N. Gowtham, J. M. Lakshmi, G. K. Savyasachi, and M. Bukya, "A novel transformer-less eleven-level inverter with optimized Buck-Boost controller and minimal switch design for grid-connected PV systems," *Automatika*, vol. 66, no. 4, pp. 950–971, 2025, doi: 10.1080/00051144.2025.2577008.